

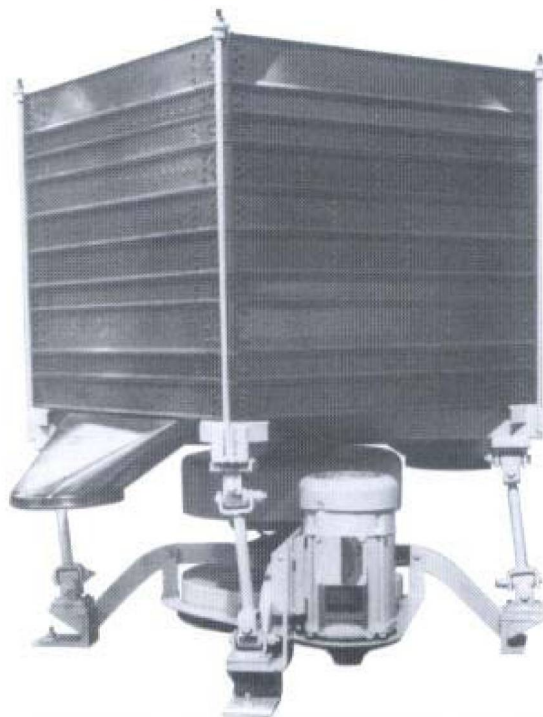

# GYRATORY SCREEN



**MODEL**  
**CS 1**

AS ORIGINALLY  
MARKETED BY THE  
ALLIS-CHALMERS  
MANUFACTURING COMPANY

**ALL METAL, SANITARY,  
MAGNESIUM ALLOY  
CONSTRUCTION**

**application** – For accurate sizing of dry, free flowing materials.  
For sanitary sizing of dry foods and food products.

**separation** – Feed sizes – 200 mesh to 1/4 inch.

**screening area** – 10 to 35 square feet available with 2 to 7  
decks for separating into 2, 3, or 4 products.

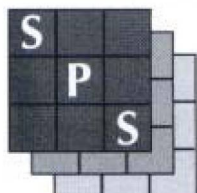

**SIFTER PARTS & SERVICE, INC.**

**CUSTOM BAGS, TUBES, SLEEVES & PARTS**

P.O. Box 7560

WESLEY CHAPEL, FL 33544

<http://www.sifterparts.com>

**Telephone: (813) 991-9400 3591**

**Fax (813) 991-9700**

**E-mail: [randy@sifterparts.com](mailto:randy@sifterparts.com)**

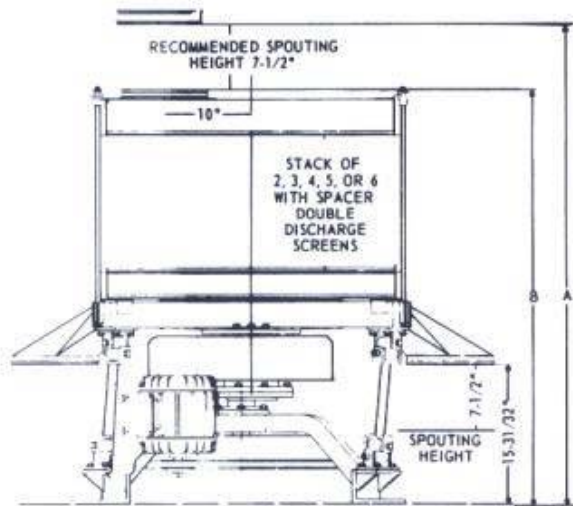

## TWO SEPARATION, DOUBLE DISCHARGE DECKS

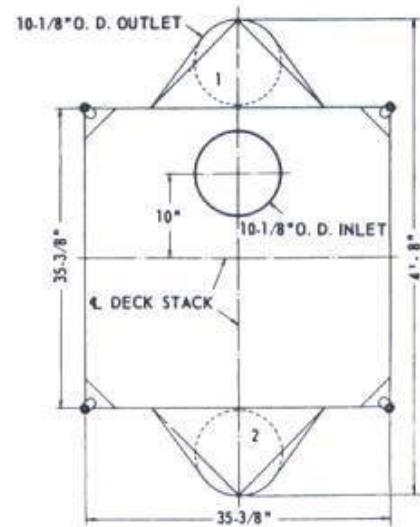

### APPROX. HEIGHT OF SCREEN

2 DECK	A = 3'11 1/16"	B = 3' 3 9/16"
3 DECK	A = 4' 3 1/16"	B = 3' 7 9/16"
4 DECK	A = 4' 6 7/16"	B = 3'10 15/16"
5 DECK	A = 4' 9 13/16"	B = 4' 2 5/16"
6 DECK	A = 5' 1 3/16"	B = 4' 5 11/16"

## TWO, THREE AND FOUR SEPARATIONS, SINGLE DISCHARGE DECKS

### APPROX. HEIGHT OF SCREEN

3 DECK	A = 4' 2 9/16"	B = 3' 7 1/16"
4 DECK	A = 4' 5 11/16"	B = 3'10 3/16"
5 DECK	A = 4' 9 13/16"	B = 4' 2 5/16"
6 DECK	A = 5' 0 7/16"	B = 4' 4 15/16"
7 DECK	A = 5' 3 13/16"	B = 4' 5 7/16"

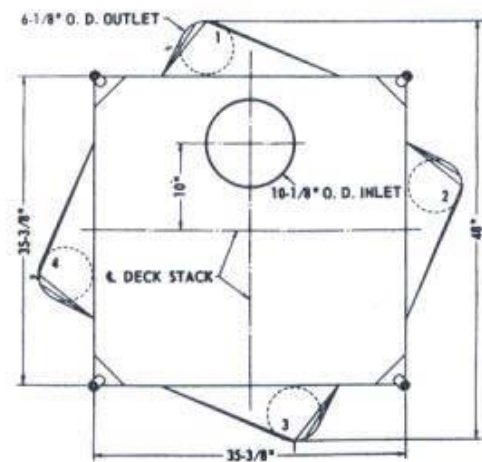
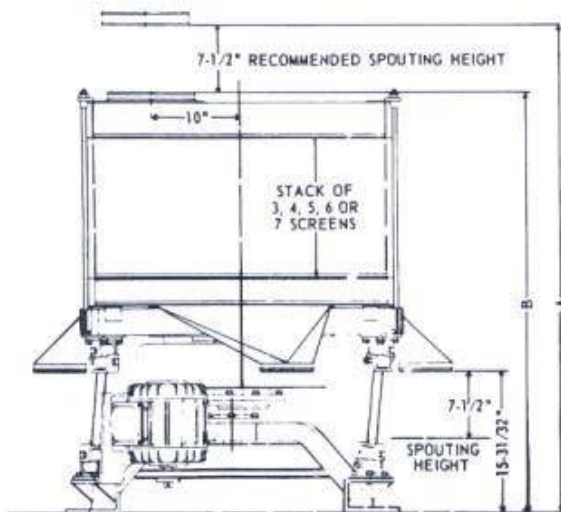

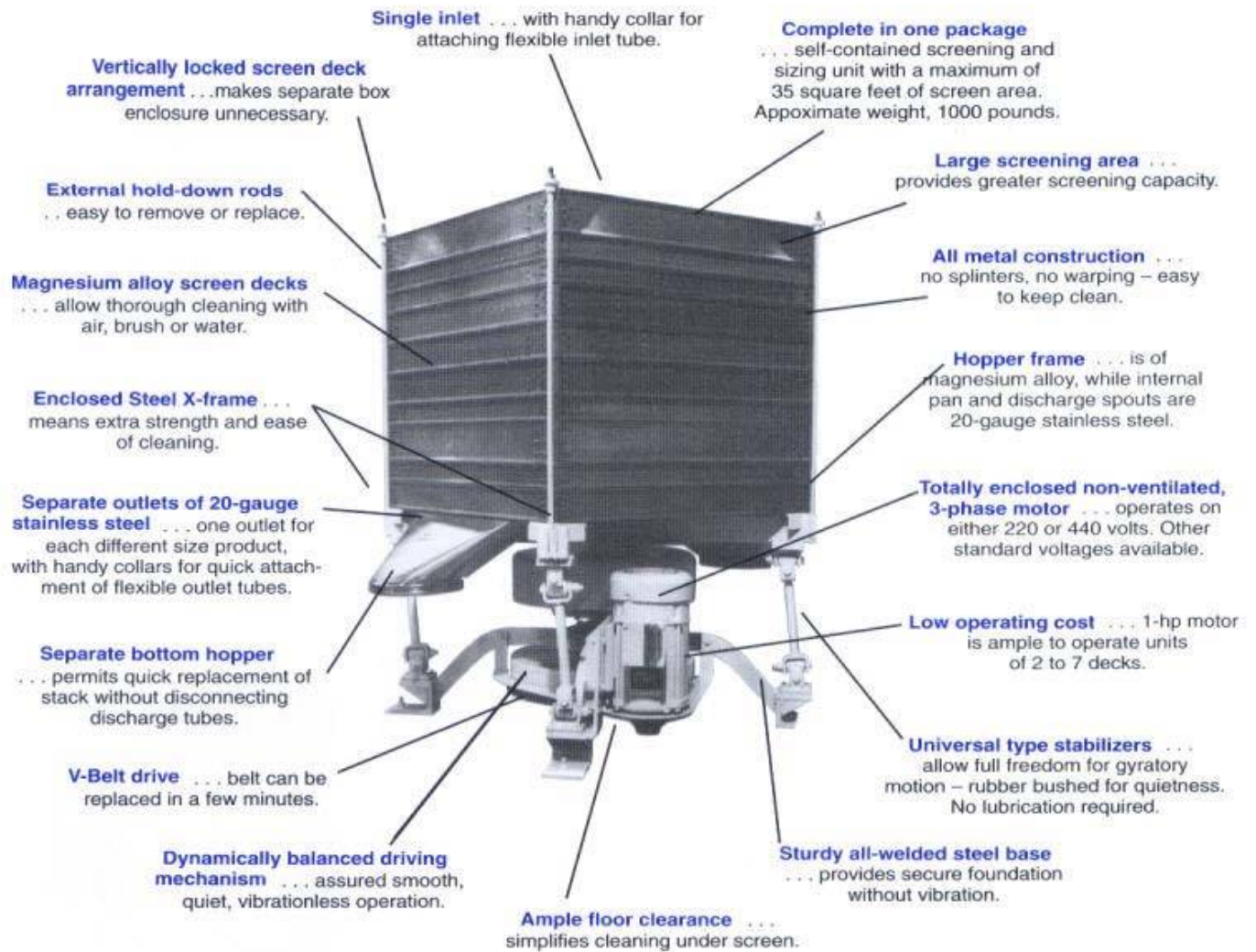

### **EASY TO INSPECT**

Inspection goes hand in hand with the cleanup operation – and assembling the machine afterward is as easy as the dismantling procedure.

### **EASY TO INSTALL**

The Model CS-1 screen is shipped as a complete unit with motor, drive and screen cloth installed. Simply bolt it to the floor or other level support, attach inlet and outlet tubes, connect it to your power source and this screen is ready to build profits.

### **EASY TO DISMANTLE**

All screen stack components are readily removable. No special tools or skills are required. After removing external rods, deck cover and individual screen decks can be lifted off easily and quickly.

### **EASY TO CLEAN**

You can clean with brush, air, water or cleaning solution. Removable screen cloth inserts snap out quickly, exposing all internal surfaces. Cleaning is accomplished in the shortest time.



Connecting sleeves; rubber products: smooth wall rubber tubing; corrugated sleeves; pressure sleeve assemblies; cleaner balls and cubes

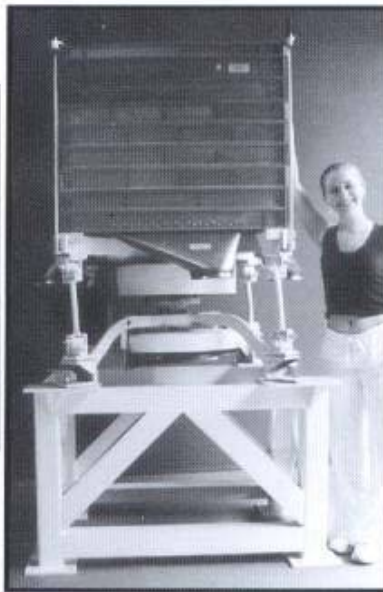

7 deck multiple separation gyratory sifter

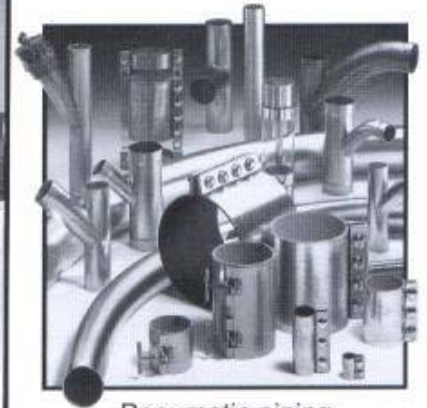

Pneumatic piping system components

OEM replacement and custom screens manufactured from wire or synthetic clothing



Rings - new or rescreened

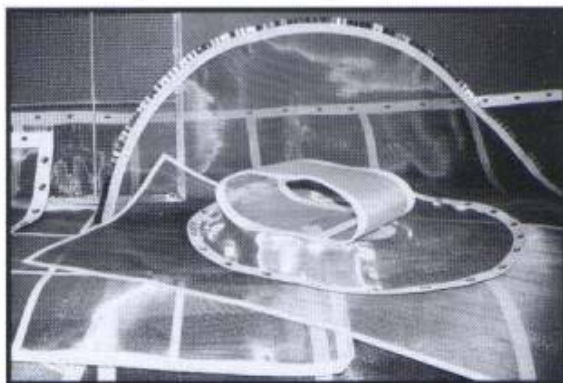

OEM replacement dust bags for most dust collectors; flame retardant treatment available

**CALL  
800-367-3591  
FREE QUOTATIONS**

**TELL US HOW YOU MEASURE!**



CIRCUMFERENCE



FLAT WIDTH

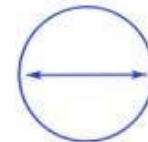

DIAMETER